

# Sphere Top Bracket

Sphere top brackets are available in various sizes and styles.

Bracket can be manufactured from a double arm up to as many arms as required.

Galvanised to BS 729.

If the bracket size you required is not listed, please specify your requirements in the table below.

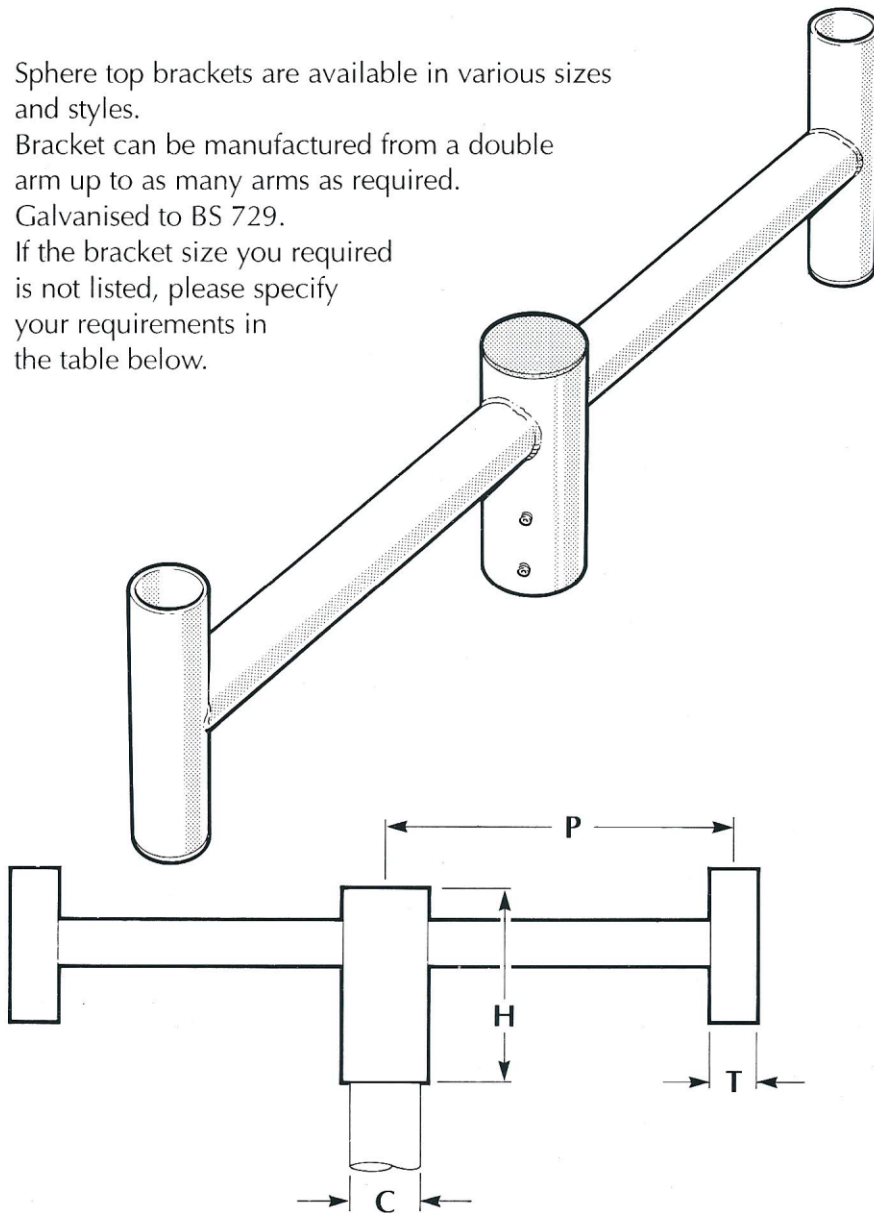

2 or 3 lamps

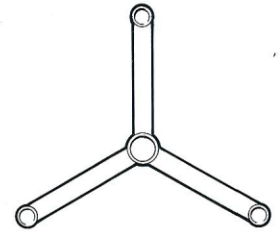

3 or 4 lamps

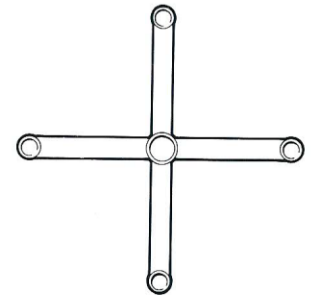

4 or 5 lamps

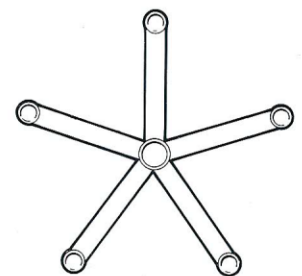

5 or 6 lamps

STANDARD BRACKET SIZES							
Part Number	C	P	T	H	Arm Angle	Number of arms	Finish
ST/3075	76	600	60	250	0°	2	Galv.
ST/3080	76	600	60	250	0°	3	Galv.
ST/3085	76	600	60	250	0°	4	Galv.

YOUR REQUIREMENTS							
C	P	T	H	Arm Angle	Number of arms	Finish	